



MANUAL



2-IN-1 WALL MOUNT /HANDY REMOTE CONTROL MYCT-2107

CONTENTS

1. Overview and features	Page 2.
2. Diagrams	Page 3.
3. Battery	Page 4.
4. Mounting on surface	Page 6.
5. Pairing / Un-pairing device	Page 8.
6. Operation	Page 9.
7. Specifications	Page 10.

1. Overview and features

2-in-1 remote / wall switch control can easily be wall mounted and or affix on any magnetic base. Use as a wall switch or as a handy remote control.

Control up to 4 different channels separately or as group control.



Main features.

- Compatible to L and M series.
- Smooth dimming control.
- 4 sets of On/Off button.
- 1 group All On / All Off feature.
- 3V CR2032 battery operation.
- Green LED indication representing different operation status.
- Easy screw mounting or on magnetic surface.

2. Diagrams.

Main Handy Remote

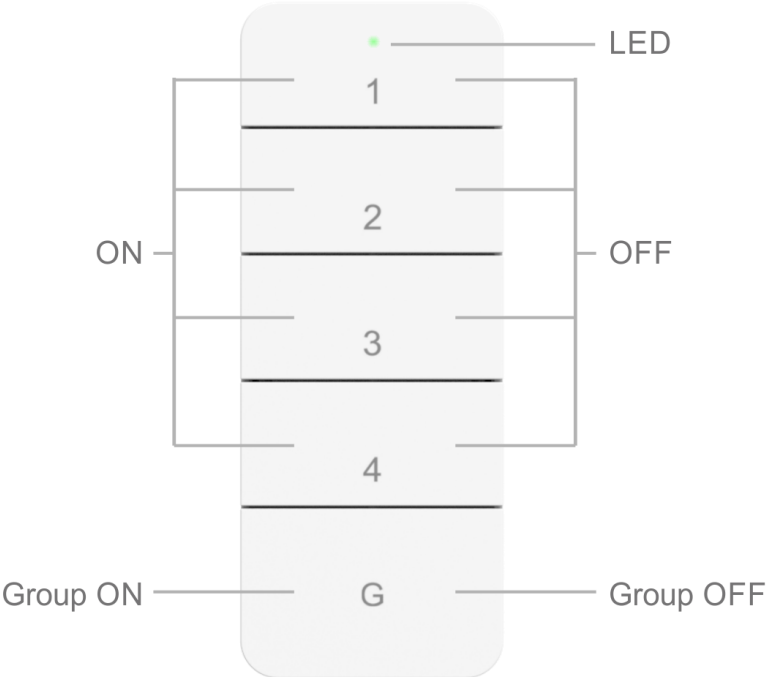

Magnetic Back Holder



3. Battery

1. With a $\Phi 3\text{mm}$ flat headed screwdriver, insert into the allocated slot and with a little force push open the battery cover then remove battery insulation stirp. (First time use only)



2. Insert flat headed screwdriver and slightly lift up to remove battery.

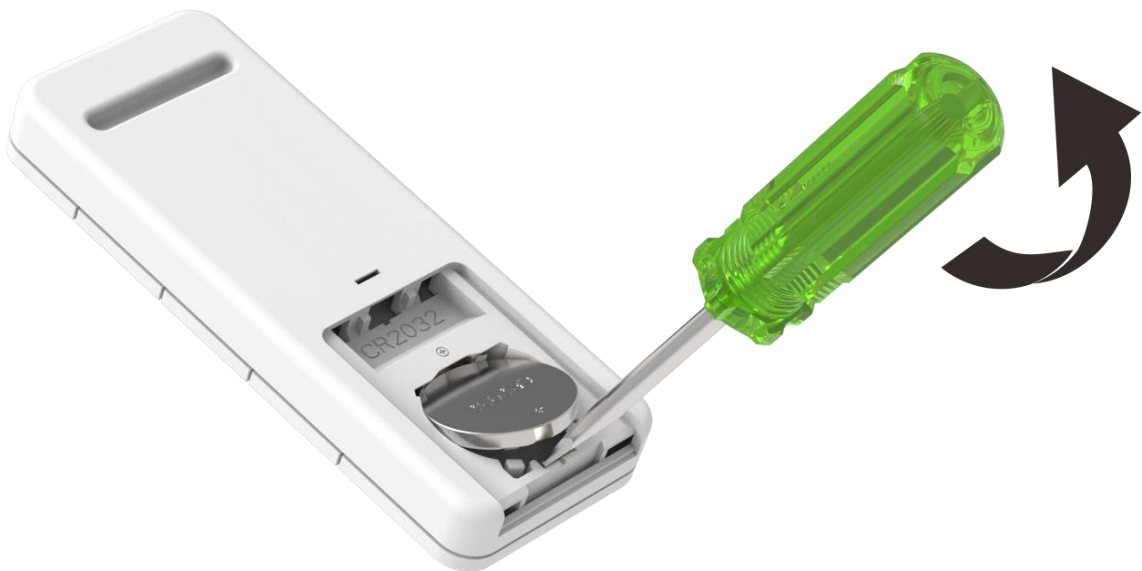

3. Insert new 3V CR2032 battery making sure the positive symbol is facing upwards.



4. Slide back the battery cover.

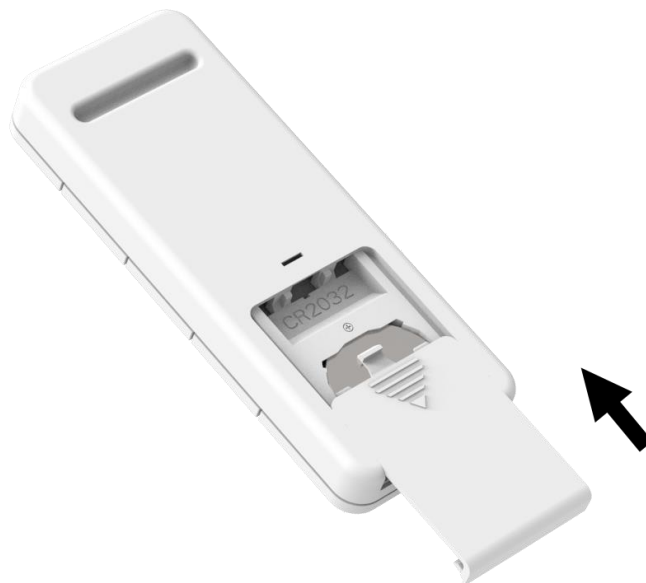

LITHIUM BATTERY CAUTION:

Risk of Explosion if battery is replaced by an incorrect type. Dispose of used batteries according to the environment protection rules.

4. Mounting On Surface

1. Insert flat headed screwdriver into the button slot and lift open the front magnetic holder.



2. Position the back magnetic holder onto surface making sure the arrow is facing up then affix tightly with 2 screws.

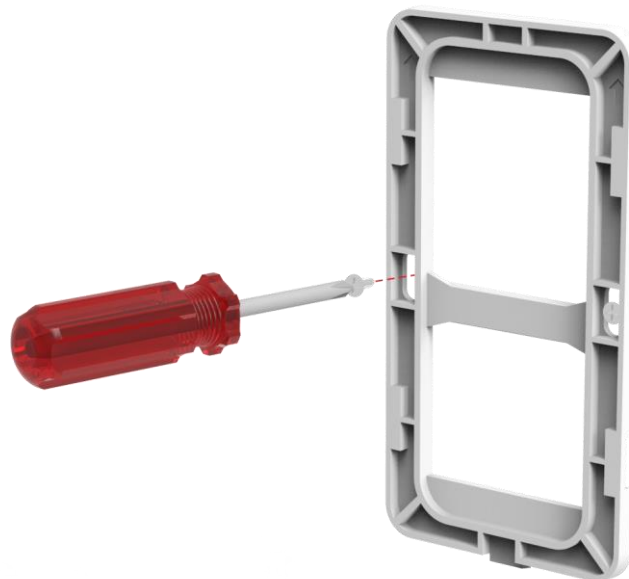

3. Align the front magnetic holder onto the 4 clips and with a little force push forward making sure 'click' sound is heard.



4. Or use the double-sided adhesive tape to stick on flat surface.

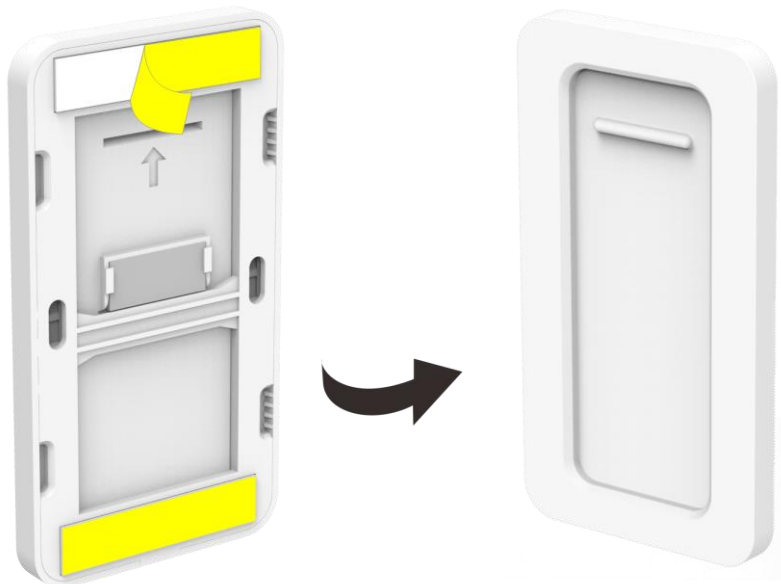

5. Pairing / Un-pairing Device

To Pair: with socket switch plug

1. On the remote control, select the desired channel (1 / 2 / 3 / 4) to pair.
2. Plug the socket switch into an electrical outlet.

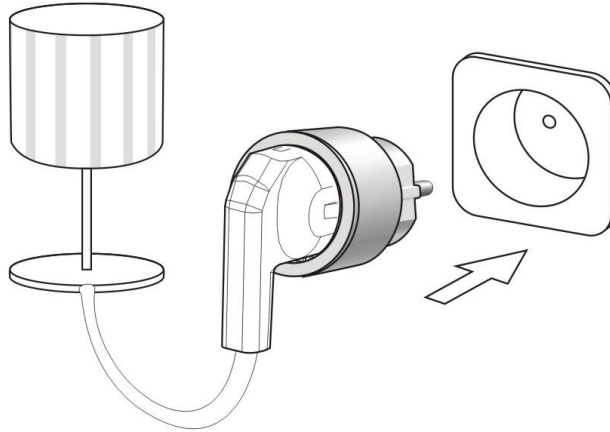

3. Within 6 seconds press **ON** button once to pair, LED will flash and load will flash twice to confirm that pairing is successful.

To Unpair: with socket switch plug

1. On the remote control, select the desired channel (1 / 2 / 3 / 4) to unpair.
2. Unplug socket switch from the electrical outlet for at least 6 seconds.

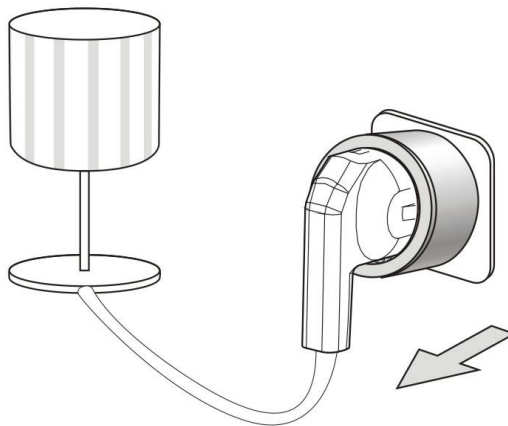

3. Plug socket switch back into electrical outlet.
4. Within 6 seconds press **OFF** button to unpair, LED will flash and load will flash twice to confirm that memory is deleted successfully.

6. Operation

ON / OFF OPERATION

Turn the load ON:

1. Press **ON** button, LED will flash once.

Turn the load OFF:

1. Press **OFF** button once, LED will flash twice.

DIMMING OPERATION

! After setting brightness level, the next time switching ON the load will return to the previous stipulated brightness.

1. With the load ON.
2. Hold down **ON** button, load will dim up or hold down **OFF** button, load will dim down.
3. At the desired load level release the button to stop.
4. During dimming process load will stop at either maximum or minimum brightness and will not continue dimming.
5. To continue dimming repeat step 2-3.

GROUP ON / OFF

Group On/Off will automatically be memorized upon pairing each channel. To control the four channels together, simply press G button **ON** or **OFF**. Dimming feature is not available in group On/Off control.

**Note, if operating with L series receiver(s) the G button feature needs to be paired individually with the normal L series pairing method.

6. Specifications

Battery:	3V CR2032 Lithium Cell Battery
Radio Frequency:	433.92MHz
Power consumption:	<1W
Environment Temperature:	0-40 °C
Range:	Up to 50 M (Depends on building materials)
In accordance with:	Low Voltage Directive 2014/35/EU RED Directive 2014/53/EU
CE Certification:	The CE marked affixed to this product confirms its compliance with the European Directives which apply to the product and in particular its compliance with the harmonized standards and specifications.



Dimension	60 x 110 x 15 mm
Weight:	55 g
Accessory pack enclosed:	2pcs double sided adhesive tape. 2pcs screws.